



CANOPIES, UPDRAFTS, DUCTWORK, EXHAUST AND MAKE UP AIR FANS



NFPA#96

APPROVAL SHEET



Standard 2

Thrift Air "TM96" Make Up Air Canopy With End Curtains

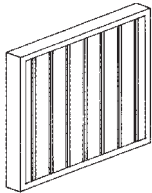
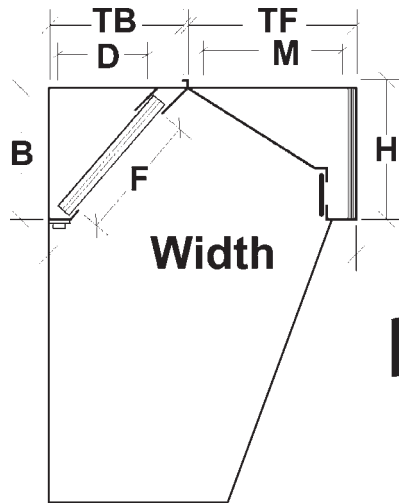
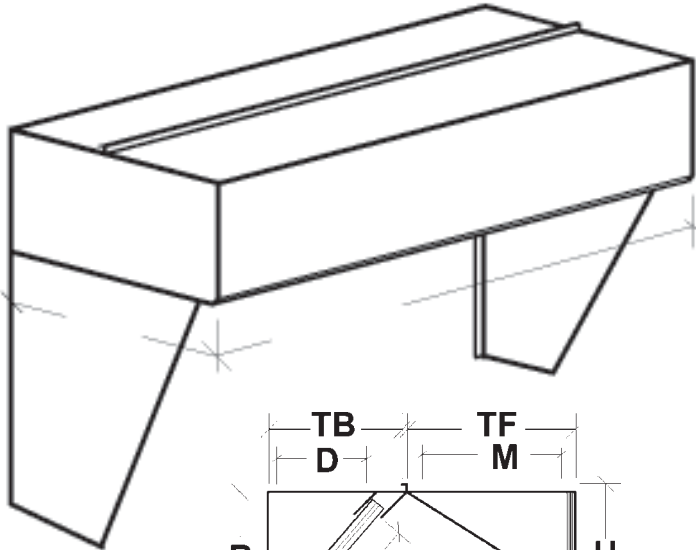

Job Name:		
Dealer:		
PO. #:	By:	Date:
Fabrication cannot begin until sheet is signed		
Approved by:		Date:

TM	DIMENSIONAL DATA						
W	B	H	TB	TF	F	D	M
36"	16½"	18"	20"	14"	16"	13"	12"
42"	16½"	18"	26"	14"	16"	16"	12"
48"	16½"	18"	20"	26"	16"	13"	24"
54"	16½"	18"	26"	26"	16"	16"	24"
60"	16½"	18"	26"	26"	16"	16"	24"

Specifications

- TM96S0 Series Thrift Air Make Up Air Canopy:** Sturdi-Bilt Compensating Canopy for air conditioned kitchens and kitchens with low ceilings constructed of 20 Gauge Stainless Steel #3 polish on all exposed surfaces. Balance 18 Gauge Aluminized Steel. All Externally Welded Seams, Code #96 Construction. Insulated Make Up Air Plenum with full length diffusers. Includes a full compliment of 20" wide U.L. Listed Aluminum Baffle Filters, Pitched Rear Grease Gutter, Grease Drain and removable Grease Cup. Front and Rear Hanger Brackets. NSF Listed, Built to NFPA #96 and International Mechanical Code Type 1 Hood Standards.
- End Curtains:** Light Gauge S/S End Curtains to improve efficiency and lower required CFM
- TM96A8 Series Thrift Air Make Up Air Exhaust Canopy:** Sturdi-Bilt Canopy same as above only constructed of 18 Gauge Aluminized Steel. All Exposed surfaces painted hammertone Gray.
- Vapor Proof Canopy Light:** Sturdi-Bilt Fireguard Canopy Light, U.L. and NSF Listed 100 Watt Incandescent Vapor and Grease proof Canopy Light. Included Plastic Coated Lime Glass Globe, Canopy Light Fixture, Mounting Plate, Junction Box, prewired to External Junction Box.

