



CANOPIES, UPDRAFTS, DUCTWORK, EXHAUST AND MAKE UP AIR FANS

APPROVAL SHEET



U. L. Air Listed WALL FANS

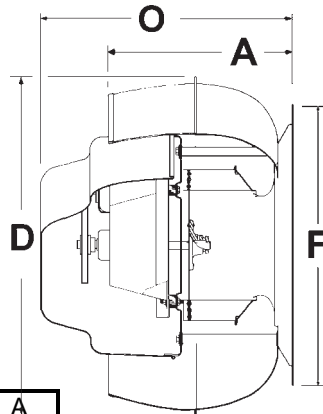
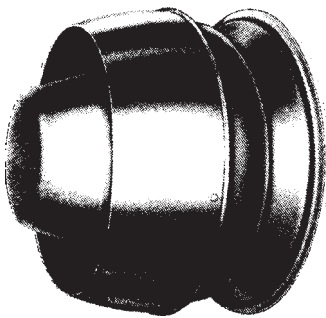

Belt Drive

Model	D	F	H	A
FW-F	30 ³ / ₄ "	25"	24 ¹ / ₄ "	18 ³ / ₄ "
FW-G	34 ³ / ₄ "	30"	29"	20"
FW-H	34 ³ / ₄ "	30"	29"	20"
FW-J	34 ³ / ₄ "	30"	29 ¹ / ₂ "	20"
FW-K	39 ¹ / ₂ "	36"	30 ¹ / ₂ "	22 ³ / ₄ "
FW-L	39 ¹ / ₂ "	36"	31 ¹ / ₂ "	22 ³ / ₄ "

Job Name:		
Dealer:		
Model	SP	CFM
P.O. #:	By:	Date:
Fabrication cannot begin until sheet is signed		
Approved by		Date

Model	HP	RPM	CFM @								
			1/8"	1/4"	3/8"	1/2"	5/8"	3/4"	7/8"	1"	1 1/4"
FW-F	1/2	1615	2418	2347	2275	2203	2130	2052	1968	1879	1621
FW-G	1/2	1355	2770	2676	2581	2486	2385	2275	2156	2015	-
FW-H	3/4	1545	3183	3101	3018	2935	2851	2765	2672	2574	2353
FW-J	3/4	1320	3608	3501	3395	3287	3178	3061	2935	2802	2413
FW-K	3/4	1090	4007	3932	3792	3645	3489	3320	3130	2903	-
FW-L	3/4	990	4605	4448	4289	4289	3909	3650	3388	3085	-

Specifications

Description: Spun Aluminum Upblast Centrifugal Wall Mounted Exhaust Ventilator. **Certifications:** Underwriters Laboratories (UL705 - Power Ventilator) and ULc listed for Canada (Power Ventilation) AMCA Certified Ratings for Sound and Air Performance. **Construction:** Bolt and Welded Construction, Spun Marine Alloy Aluminum, quick release Latch Removal Top, External Wiring Compartment with Integral Conduit Chase to Motor Compartment, 14 gauge Steel Power Assembly, Rolled Bead on Windband, bolted to a rigid Aluminum support Structure. Weatherproof construction, drains water away from the wall. **Wheel:** 100% Aluminum Centrifugal Backward included, Balanced to AMCA Standard 204-96. **Motor:** Heavy Duty, Permanently Lubricated Sealed Ball Bearing. **Bearings:** Heavy Duty re-greasable Ball type Bearings in a Cast Iron Housing, minimum L50 life in excess of 200,000 hours. **Belts and Drives:** Heat and Oil Resistant Belt, Variable Pitch Motor Drive, Cast Iron Pulleys sized for 150% of installed Motor Horsepower. **Disconnect Switch:** NEMA 3R Exterior Rain Tight Covered Safety Disconnect Switch, Prewired.

Option: Two Speed Fan