

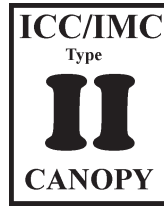

CANOPIES, UPDRAFTS, DUCTWORK, EXHAUST AND MAKE UP AIR FANS



APPROVAL SHEET



Standard 2

Conveyor Oven Canopys

"D1" Series "Cap" Style

Type II Baking consists of the baking, and rethermalizing of precooked items. The use of *any* uncooked meat requires the use of a Type I Hood.

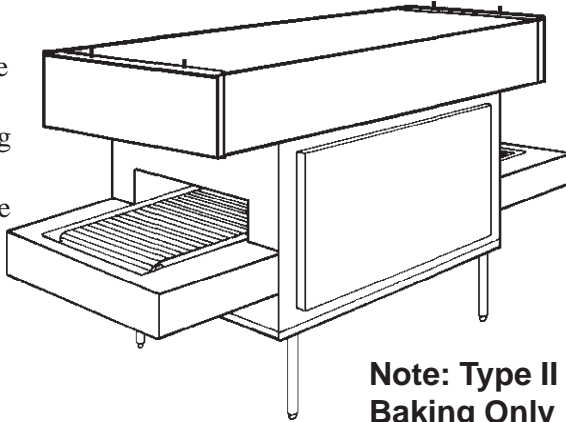

Note: Type II Baking Only

Job Name:		
Dealer:		
P.O. #:	Date:	
Oven Make	Oven Model	
Canopy Model	Date:	By:

D1 Series

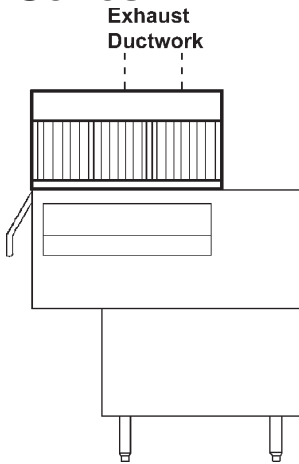

Overhang Overhang

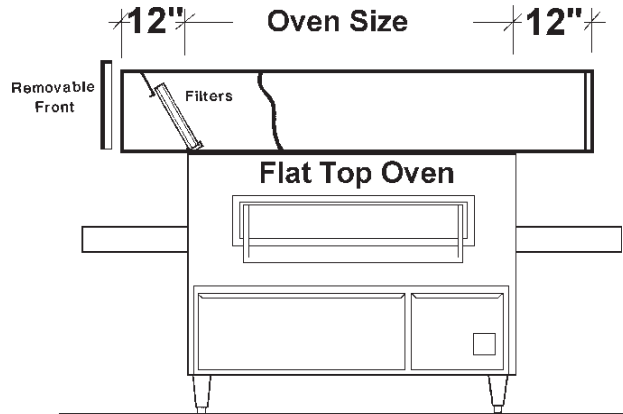

Flat Top Oven

Specifications

- "D1S" Series Conveyor Oven Canopy:** Constructed of minimum 20 Gauge Stainless Steel Where Shows, 20 Gauge Minimum Aluminized Steel Back, Bottom and Top, Welded Construction. 12" Overhang for flat top single deck ovens. Air Filter Panel. Ceiling hung, designed to mount directly over the oven. International Mechanical Type II Hood, NSF Listed. All Canopys custom built to fit specified Conveyor Oven, Oven Make and Model must be specified.
- "D1A" Series Conveyor Oven Canopy:** Same as above, only constructed of all minimum 20 Gauge Aluminized Steel, Painted Hammertone Gray exposed Front and Ends.
- Type 1 NFPA #96 Construction:** Constructed of 18 Gauge all externally welded construction, UL Grease Listed Baffle Filters, pitched gutter, grease cup.
- Flue:** Canopy does not ventilate flue. Direct Vent Flue Vent is required.