

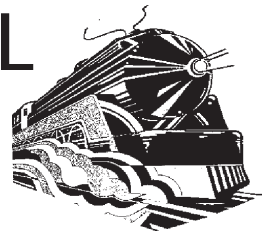

CANOPIES, UPDRAFTS, DUCTWORK, EXHAUST AND MAKE UP AIR FANS



APPROVAL SHEET



Economy

Low Side Wall Ventilator 17" Wide

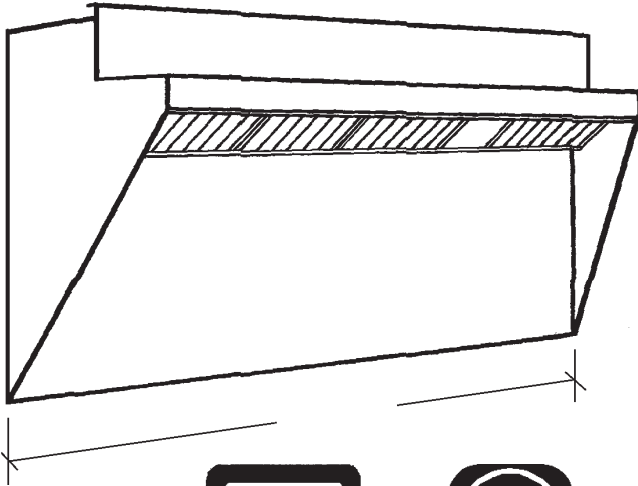

Job Name:		
Dealer:		
Updraft Model	By:	Date:
Fabrication cannot begin until sheet is signed		
Approved by	PO Number	Date

Options



NFPA#96



Standard 2

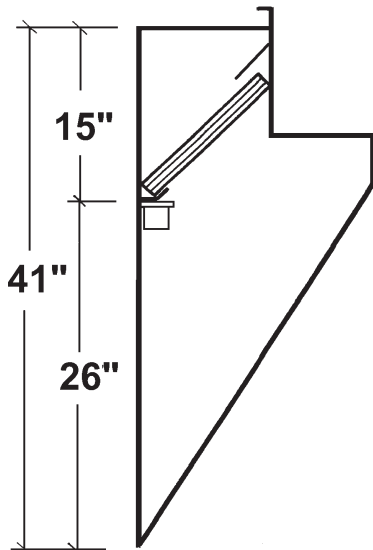
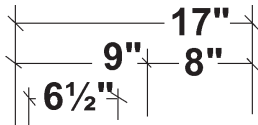

Specifications

U96TS Series Ventilator: Constructed of Stainless Steel on all exposed surfaces. Ventilation Section constructed of 20 Gauge Stainless Steel and 18 Gauge Aluminized Steel. All Seams externally welded. Code #96 construction. Stainless Steel Plate Shelf, Back Panel and Top Ends. Includes a full complement of 20" wide U.L. Grease Listed Aluminum Baffle Filters, pitched Grease Gutter, Grease Drain, and removable S/S Covered Grease cup. NSF Listed. Built to NFPA Standard #96, International Mechanical Code Type I Specifications for Low Side Wall Canopies.

U96TA Series Ventilator: Same as above only constructed of 18 Gauge Aluminized Steel. Painted Hammertone Gray Exposed Exterior.

UL 710 and Canada
 CSA C22.2 No 113
 Exhaust Hood Recognized

UL 710



Can CSA C22.2

